

Homogeneous Catalysis in Supercritical Fluids: Hydrogenation of Supercritical Carbon Dioxide to Formic Acid, Alkyl Formates, and Formamides

Philip G. Jessop, Yi Hsiao, Takao Ikariya, and Ryoji Noyori*[†]

Contribution from ERATO Molecular Catalysis Project, 1247 Yachigusa, Yakusa-cho, Toyota 470-03, Japan

Received September 7, 1995[⊗]

Abstract: Rapid, selective, and high-yield hydrogenation of CO₂ can be achieved if the CO₂ is in the supercritical state (scCO₂). Dissolving H₂, a tertiary amine, a catalyst precursor such as RuH₂[P(CH₃)₃]₄ or RuCl₂[P(CH₃)₃]₄, and a promoting additive such as water, CH₃OH, or DMSO in scCO₂ at 50 °C leads to the generation of formic acid with turnover frequencies up to or exceeding 4000 h⁻¹. In general, experiments in which a second phase was formed by one or more reagents or additives had lower rates of reaction. The high rate of reaction is attributed to rapid diffusion, weak catalyst solvation, and the high miscibility of H₂ in scCO₂. The formic acid synthesis can be coupled with subsequent reactions of formic acid, for example, with alcohols or primary or secondary amines, to give highly efficient routes to formate esters or formamides. With NH(CH₃)₂, for example 420 000 mol of dimethylformamide/mol of Ru catalyst was obtained at 100 °C. The demonstrated solubility and catalytic activity of complexes of tertiary phosphines in scCO₂ suggest that scCO₂ could be an excellent medium for homogeneous catalysis and that many phosphine-containing homogeneous catalysts could be adopted for use in supercritical media.

Introduction

Supercritical fluids (SCFs), substances heated beyond their critical point, have densities and viscosities between those of liquids and gases. SCFs, especially supercritical carbon dioxide (scCO₂; T_c = 31 °C, P_c = 72.9 atm),¹ have been used as solvents for extractions,^{2,3} chromatography, stoichiometric organic reactions, and heterogeneously catalyzed reactions^{4–7} but, with few exceptions,^{8–14} have not been used for homogeneously catalyzed reactions. The benefits of SCFs suggest that for some reactions, the yield, rate, or selectivity will be dramatically enhanced. Among the chemical advantages, the most pertinent to homogeneous catalysis in scCO₂ is the miscibility of gases such as

H₂ with scCO₂.¹⁵ The concentration of H₂ in a supercritical mixture of H₂ (85 atm) and CO₂ (120 atm) at 50 °C is 3.2 M, while the concentration of H₂ in THF under the same pressure is merely 0.4 M.¹⁶ This property of scCO₂ must allow significant rate enhancement of reactions for which the rate is greater than zeroth order in H₂ concentration. The usefulness of this property has been noted previously.^{8,9} The high concentration of CO₂ in scCO₂ could also be advantageous in any reaction which incorporates CO₂. It is possible therefore that the use of scCO₂ as a solvent will allow the more widespread use of CO₂ as an organic carbon source; we present here, and in our preliminary communications^{12,17,18} and patents,^{11,19–21} examples of this strategy.^{22,23}

Carbon dioxide is an abundant and nonharmful source of carbon for incorporation into organic molecules. The lack of reactivity of the molecule has prevented CO₂ from becoming a carbon source for more than the production of urea, aspirin, and carbonates.²⁴ Another possible reaction is the hydrogenation of CO₂ to formic acid, which is rendered thermodynamically favorable by the addition of a base (eq 1).

[†] Permanent address: Department of Chemistry, Nagoya University, Chikusa, Nagoya 464-01, Japan.

[⊗] Abstract published in *Advance ACS Abstracts*, December 15, 1995.

(1) (a) Reid, R. C.; Prausnitz, J. M.; Poling, B. E. *The Properties of Gases and Liquids*, 4th ed.; McGraw-Hill: New York, 1987. (b) *International Tables of the Fluid State*; Angus, S., Armstrong, B., de Reuck, K. M., Eds.; Pergamon Press: Oxford, 1976; Vol. 3 (Carbon Dioxide).

(2) Eckert, C. A.; Van Alsten, J. G.; Stoicos, T. *Environ. Sci. Technol.* **1986**, *20*, 319–325.

(3) McHugh, M. A.; Krukonic, V. J. *Supercritical Fluid Extraction*; Butterworths: Boston, 1986.

(4) Subramaniam, B.; McHugh, M. A. *Ind. Eng. Chem. Process Des. Dev.* **1986**, *25*, 1–12.

(5) Brennecke, J. F. In *Supercritical Fluid Engineering Science: Fundamentals and Applications*; Kiran, E., Brennecke, J. F., Eds.; ACS Symposium Series 514; American Chemical Society: Washington, DC, 1993; pp 201–219.

(6) Shaw, R. W.; Brill, T. B.; Clifford, A. A.; Eckert, C. A.; Franck, E. U. *Chem. Eng. News* **1991**, *69* (51), 26–39.

(7) Kaupp, G. *Angew. Chem., Int. Ed. Engl.* **1994**, *33*, 1452–1455.

(8) Kramer, G. M.; Leder, F. U.S. Patent 3 880 945, 1975.

(9) Rathke, J. W.; Klingler, R. J.; Krause, T. R. *Organometallics* **1991**, *10*, 1350–1355.

(10) Vieville, C.; Mouloungui, Z.; Gaset, A. *Ind. Eng. Chem. Res.* **1993**, *32*, 2065–2068.

(11) Ikariya, T.; Jessop, P. G.; Noyori, R. Japan Patent Appl. No. 274721, 1993.

(12) Jessop, P. G.; Ikariya, T.; Noyori, R. *Nature* **1994**, *368*, 231–233.

(13) Jessop, P. G.; Ikariya, T.; Noyori, R. *Science* **1995**, *269*, 1065–1069.

(14) Burk, M. J.; Feng, S.; Gross, M. F.; Tumas, W. *J. Am. Chem. Soc.* **1995**, *117*, 8277–8278.

(15) Tsang, C. Y.; Strett, W. B. *Chem. Eng. Sci.* **1981**, *36*, 993–1000.

(16) *Hydrogen and Deuterium*; Young, C. L., Ed.; Solubility Data Series; Pergamon Press: Oxford, 1981; Vol. 5/6.

(17) Jessop, P. G.; Hsiao, Y.; Ikariya, T.; Noyori, R. *J. Am. Chem. Soc.* **1994**, *116*, 8851–8852.

(18) Jessop, P. G.; Hsiao, Y.; Ikariya, T.; Noyori, R. *J. Chem. Soc., Chem. Commun.* **1995**, 707–708.

(19) Ikariya, T.; Jessop, P. G.; Noyori, R. Japan Patent Appl. No. 125401, 1994.

(20) Ikariya, T.; Jessop, P. G.; Hsiao, Y.; Noyori, R. Japan Patent Appl. No. 125402, 1994.

(21) Ikariya, T.; Hsiao, Y.; Jessop, P. G.; Noyori, R. Eur. Patent Appl. 0 652 202, 1995.

(22) Concurrent but independent work on the use of scCO₂ as a medium and reactant for its reaction with an alkyne, catalyzed by a nickel–phosphine complex, was the subject of a communication by Reetz et al.²³

(23) (a) Reetz, M. T.; Könen, W.; Strack, T. *Chimia* **1993**, *47*, 493. (b) Banister, J. A.; Lee, P. D.; Poliakov, M. *Organometallics* **1995**, *14*, 3885, footnote 5.

(24) Keim, W. In *Carbon Dioxide as a Source of Carbon*; Aresta, M., Forti, G., Eds.; NATO ASI Series, Series C 206; D. Reidel: Dordrecht, 1987; pp 23–31.



Although this reaction and variations thereof have been known for 2 decades,^{25–27} efficient systems for its homogeneous catalysis have only recently been reported,²⁸ especially by the team of Leitner et al.^{29–33} Surprisingly, the highest conversion (TON = 3400)³¹ has been obtained with water as the solvent (TON = turnover number, mol of product/mol of catalyst).³⁴ We have reported in a preliminary communication that the hydrogenation of CO₂ is particularly efficient if the CO₂ is in the supercritical state.^{11,12} Since then, we have expanded the range of conditions and additives tested and investigated a number of other factors which influence rate and yield.

The related syntheses of alkyl formate^{18,19} and formamides^{17,20} from scCO₂ have also been investigated in our laboratory. Methyl formate is used for the industrial synthesis of formic acid and DMF, as well as for other applications.³⁵ It can be produced by the base-catalyzed carbonylation of methanol with CO, the currently used industrial process, by methanol dehydrogenation³⁶ or by hydrogenation of CO₂ in the presence of methanol (eq 2).²⁸

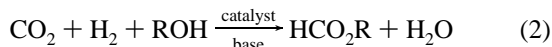

Homogeneous catalysts for this process include RuH₂[P(C₆H₅)₃]₄,^{26,27,37} other metal–phosphine complexes,^{26,27,38,39} and anionic carbonyl complexes.^{40–42} The temperatures used by previous investigators were unfortunately high (100–175 °C), while the highest reported yield was 470 TON, obtained in methanol solution with inorganic bases.³⁸

Dimethylformamide (DMF), an important industrial solvent, is currently prepared by the sodium methoxide-catalyzed carbonylation of dimethylamine with CO in methanol.⁴³ The synthesis of formamides from CO₂, H₂, and dialkylamines (eq

(25) Haynes, P.; Slauch, L. H.; Kohnle, J. F. *Tetrahedron Lett.* **1970**, 365–368.

(26) Kolomnikov, I. S.; Lobeveva, T. S.; Vol'pin, M. E. *Izv. Akad. Nauk SSSR, Ser. Khim.* **1972**, 2329–2330.

(27) Inoue, Y.; Sasaki, Y.; Hashimoto, H. *J. Chem. Soc., Chem. Commun.* **1975**, 718–719.

(28) Jessop, P. G.; Ikariya, T.; Noyori, R. *Chem. Rev.* **1995**, *95*, 259–272.

(29) Graf, E.; Leitner, W. *J. Chem. Soc., Chem. Commun.* **1992**, 623–624.

(30) Burgemeister, T.; Kastner, F.; Leitner, W. *Angew. Chem., Int. Ed. Engl.* **1993**, *32*, 739–741.

(31) Gassner, F.; Leitner, W. *J. Chem. Soc., Chem. Commun.* **1993**, 1465–1466.

(32) Leitner, W.; Dinjus, E.; Gassner, F. *J. Organomet. Chem.* **1994**, *475*, 257–266.

(33) Fornika, R.; Görls, H.; Seemann, B.; Leitner, W. *J. Chem. Soc., Chem. Commun.* **1995**, 1479–1481.

(34) A recent publication has described a Ru catalyst system for the hydrogenation of CO₂ in ethanol with TON values of up to 5000 at 150 °C; see: Lau, C. P.; Chen, Y. Z. *J. Mol. Catal. A: Chem.* **1995**, *101*, 33–36.

(35) Reutemann, W.; Kieczka, H. In *Ullmann's Encyclopedia of Industrial Chemistry*, 5th ed.; Elvers, B., Hawkins, S., Ravenscroft, M., Rounsaville, J. F., Schulz, G., Eds.; VCH: Weinheim, 1989; Vol. A12, pp 13–33.

(36) Weissermel, K.; Arpe, H.-J. *Industrial Organic Chemistry*, 2nd ed.; VCH: Weinheim, 1993; pp 39–43.

(37) Hashimoto, H.; Inoue, Y. Japan Kokai Tokkyo Koho 138614, 1976.

(38) Lodge, P. G.; Smith, D. J. H. Eur. Patent Appl. 0 094 785, 1983.

(39) Phala, H.; Kudo, K.; Mori, S.; Sugita, N. *Bull. Inst. Chem. Res., Kyoto Univ.* **1985**, *63*, 63–71.

(40) Darensbourg, D. J.; Ovalles, C. *J. Am. Chem. Soc.* **1984**, *106*, 3750–3754.

(41) Evans, G. O.; Newell, C. J. *Inorg. Chim. Acta* **1978**, *31*, L387–L389.

(42) Darensbourg, D. J.; Ovalles, C.; Pala, M. *J. Am. Chem. Soc.* **1983**, *105*, 5937–5939.

(43) Bipp, H.; Kieczka, H. In *Ullmann's Encyclopedia of Industrial Chemistry*, 5th ed.; Elvers, B., Hawkins, S., Ravenscroft, M., Rounsaville, J. F., Schulz, G., Eds.; VCH: Weinheim, 1989; Vol. A12, pp 1–12.

3) catalyzed by RuH₂[P(C₆H₅)₃]₄, RuCl₂[P(C₆H₅)₃]₃, and other catalyst precursors has been reported,^{25,28,44–47} the highest yield of DMF being 3400 TON at 130 °C.⁴⁴



In this report, we present the details of our research using scCO₂, emphasizing the often dramatic effects of phase changes on reaction behavior and the strong promoting ability of additives.

Experimental Section

Materials and Methods. The compounds RuH₂[P(C₆H₅)₃]₄,⁴⁸ RuH₂[P(CH₃)₃]₄ (**1**),⁴⁹ RuCl₂[P(CH₃)₃]₄ (**2**),^{50,51} RuCl(O₂CCH₃)[P(CH₃)₃]₄ (**3**),⁵² *trans*-RuCl₂(dmpe)₂,⁵³ *trans*-RuHCl(dmpe)₂,⁵⁴ and [RhCl(nbd)]₂⁵⁵ and the carbamates⁵⁶ were prepared by literature methods (nbd = 2,5-norbornadiene; dmpe = (CH₃)₂PCH₂CH₂P(CH₃)₂). Note that complex **1** is light-sensitive and should be stored in the dark. Ru₃(CO)₁₂ (Strem) was used as received. The catalyst precursors and the alkylphosphines were stored and handled under argon at all times, except for **2** and **3** which could be weighed under air if afterwards returned to an inert atmosphere. Liquid reagents and solvents were dried, distilled, and degassed before use except for DMSO, amines, and water which were only degassed. MS3A (Nacalai) was activated and the acidic resins Nafion NR50 (DuPont) and Amberlyst (Aldrich) were washed and dried under vacuum before use. The H₂ gas used was 99.99% purity, zero grade product of Sumitomo. Two grades of CO₂ were used for formic acid production, 99.99% (Showa Tansan) and normal grade (Fuji), with comparable results. For the formamide and alkyl formate syntheses, only the purer grade was used, although the normal grade could again be satisfactory. CO (Sumitomo Seika) was UHP grade.

Spectroscopic and chromatographic measurements were performed with a JEOL JNM EX-400 NMR spectrometer, a JASCO FT/IR-5300 spectrometer, and a Shimadzu Parvum GC/MS instrument consisting of a GC-17A gas chromatograph and a QP-5000 mass spectrometer. Differential scanning calorimetry (DSC) measurements were performed under argon with a Rigaku DSC 8230B instrument and a TAS 100 system controller. The supercritical fluid equipment, a diagram of which is shown in Figure 1, was modified from supercritical chromatography equipment manufactured by JASCO International. The principal components are a stainless steel 50-, 150-, or 300-mL reactor vessel, two PU-980 HPLC pumps, an 880-81 back-pressure regulator, a CO-965 (maximum 80 °C) or 866-CO (100 °C) column oven, and a magnetic stir plate. One of the pumps was fitted with a liquid CO₂ reservoir cooled by a SCINICS CH-201 coolant circulator. The other pump was used to supply CH₂Cl₂ during the flushing procedure; the 1/16 in. stainless steel tubing of the equipment was flushed between reactions with CH₂Cl₂, CO₂, and H₂, in that order. For safety reasons, the back-pressure regulator was set to vent at 40 atm higher than the desired total pressure and was tested before every reaction.

Safety Warning. Operators of high-pressure equipment such as that required for these experiments should take proper precautions, including

(44) Kiso, Y.; Saeki, K. Japan Kokai Tokkyo Koho 36617, 1977.

(45) Kudo, K.; Phala, H.; Sugita, N.; Takezaki, Y. *Chem. Lett.* **1977**, 1495–1496.

(46) Phala, H.; Kudo, K.; Sugita, N. *Bull. Inst. Chem. Res., Kyoto Univ.* **1981**, *59*, 88–105.

(47) Schreiner, S.; Yu, J. Y.; Vaska, L. *Inorg. Chim. Acta* **1988**, *147*, 139–141.

(48) Young, R.; Wilkinson, G. *Inorg. Synth.* **1977**, *17*, 75–77.

(49) Hartwig, J. F.; Andersen, R. A.; Bergman, R. G. *Organometallics* **1991**, *10*, 1875–1887.

(50) Jones, R. A.; Real, F. M.; Wilkinson, G.; Galas, A. M. R.; Hursthouse, M. B.; Malik, K. M. A. *J. Chem. Soc., Dalton Trans.* **1980**, 511–518.

(51) Schmidbaur, H.; Blaschke, G. *Z. Naturforsch. Teil B* **1980**, *35*, 584–587.

(52) Mainz, V. V.; Andersen, R. A. *Organometallics* **1984**, *3*, 675–678.

(53) Chatt, J.; Hayter, R. G. *J. Chem. Soc.* **1961**, 896–904.

(54) Chatt, J.; Hayter, R. G. *J. Chem. Soc.* **1961**, 2605–2611.

(55) Abel, E. W.; Bennett, M. A.; Wilkinson, G. *J. Chem. Soc.* **1959**, 3178–3182.

(56) Theodoropoulos, S. Eur. Patent Appl. 0 062 161, 1982.

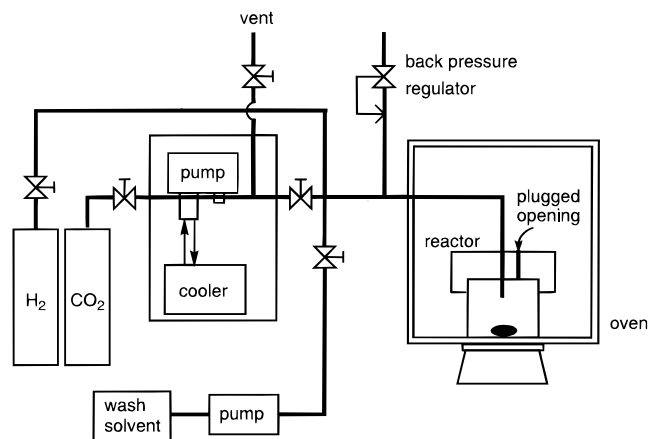

Figure 1. Equipment used for the reactions in scCO_2 .

but not limited to the use of blast shields and pressure relief mechanisms, to minimize the risk of personal injury.

Phase Behavior Observations. The phase behavior of the multicomponent systems was determined visually by use of a 50-mL reactor equipped with sapphire windows. Quantitative measurements of the concentration of amine were also performed. In the latter method, a sample loop was used to transfer a sample from the uppermost phase of the reactor vessel into a supercritical fluid chromatography system with a scCO_2 /methanol mobile phase, a Superpak Crest C18 column, a JASCO UV-970 UV detector, and an 880-81 back-pressure regulator.

Hydrogenation of scCO_2 to Formic Acid. The oven-dried reactor (usually 50-mL internal volume) was cooled to room temperature under vacuum, filled with argon, and then charged with the catalyst precursor (typically 3 μmol) in an argon-filled glovebag. The reactor was then evacuated for 10 min under high vacuum and refilled with argon. Water (2 μL , 0.1 mmol) and $\text{N}(\text{C}_2\text{H}_5)_3$ (0.7 mL, 5.0 mmol) were injected into the reactor against a positive argon pressure through a threaded opening in the top which was plugged at all other times. The reactor was then attached to the equipment as shown in Figure 1. Pressure testing and warming to the reaction temperature were performed with a pressure of 40 atm of H_2 . After temperature equilibration, which takes ca. 2 h, the pressure of H_2 was topped up to the desired level followed by the required pressure of CO_2 . The pressures cited are at reaction temperature. The CO_2 was introduced from a cooled (-5°C) reservoir by an HPLC pump. The start of the reaction is defined as the time of CO_2 gas introduction. An experiment with a reaction time of 0 h was performed to confirm that no formic acid is generated during the prewarming. After the expiration of the desired reaction time, the reactor was half-submerged in a bath of acetone or alcohol which was subsequently cooled by addition of dry ice. The use of a liquid nitrogen bath, which was also effective, is not recommended because it is more likely to cause weakening of the reactor walls. After the pressure had reached a steady low value, the H_2 gas was vented and the reactor was slowly warmed, the CO_2 venting into a fume hood as it sublimed. The formic acid to amine molar ratio (hereafter referred to as AAR) and the yield of formic acid were determined from ^1H NMR spectra of the CD_3OD solutions with 0.05 mL of CHCl_3 as an internal standard at 24°C with 16 scans at 5-s intervals and a pulse width of 5.2 μs . The accuracy of this method was confirmed by analyzing known mixtures of formic acid and $\text{N}(\text{C}_2\text{H}_5)_3$ in CD_3OD with an average error of 3% in the AAR. The identification and yield of formic acid were confirmed, for selected reactions, by GC/MS (30 m \times 0.25 cm TC-wax column, 100–200 $^\circ\text{C}$ at 20 $^\circ\text{C}/\text{min}$, 100:1 split injection, 50 kPa He carrier gas, HCO_2H monitored at 46 m/z , internal standard *n*-hexadecane monitored at 85 m/z).

Synthesis of Alkyl Formates. The alkyl formate syntheses were performed by the same method as the formic acid synthesis, except that higher temperatures were used and alcohols rather than water were added. The reaction mixtures were analyzed in the manner described for the production of formic acid except that the deuterated solvent was CDCl_3 and the internal standard the methyl peak of toluene. Additional confirmation of the identification and yield of methyl formate was obtained, for selected reactions, by GC/MS (30 m \times 0.25 cm TC-wax column, 40 $^\circ\text{C}$ for 3 min followed by ramping to 100 $^\circ\text{C}$ at 20

$^\circ\text{C}/\text{min}$, 50:1 split injection, 10 kPa He carrier gas, HCO_2CH_3 monitored at 60 m/z , internal standard acetonitrile monitored at 41 m/z).

Synthesis of Formamides. The syntheses of formamides were performed by the same method as the formic acid synthesis, except that primary and secondary amines and higher temperatures were used and neither water nor $\text{N}(\text{C}_2\text{H}_5)_3$ was added. For experimental convenience, some of the lighter amines were introduced as the corresponding carbamates rather than the free amines. For example, both dimethylamine and dimethylammonium dimethylcarbamate were tested, with identical results. Although the carbamates contain CO_2 , tests showed that very little conversion to formic acid or formamide takes place during the temperature equilibration. The product analysis and identification of the formamides and $\text{N}(\text{CH}_3)_3$ were performed by NMR in the same manner as for methyl formate. The identification and yield of DMF were also confirmed, for selected reactions, by GC/MS (30 m \times 0.25 cm TC-wax column, 50–220 $^\circ\text{C}$ at 20 $^\circ\text{C}/\text{min}$, 50:1 split injection, 100 kPa He carrier gas, DMF monitored at 73 m/z , internal standard *n*-hexadecane monitored at 85 m/z). It was not possible to obtain confirmation of the identification of $\text{N}(\text{CH}_3)_3$ by GC/MS due to its high volatility and low yield.

Stoichiometric Reaction of $\text{RuH}_2[\text{P}(\text{CH}_3)_3]_4$ with CO_2 . Carbon dioxide was bubbled for 1 min through a solution of the complex in C_6D_6 prepared under argon. Comparison of the ^1H and $^{31}\text{P}\{^1\text{H}\}$ NMR spectra before and after the reaction showed that the only product was *cis*- $\text{RuH}(\text{O}_2\text{CH})[\text{P}(\text{CH}_3)_3]_4$ in 9% conversion. The complex was not isolated. ^1H NMR (C_6D_6 , 400 MHz): δ -8.10 (dq, 1H, $^2J_{\text{HtransP}} = 99.8$ Hz, $^2J_{\text{HcisP}} = 27.7$ Hz, RuH), 0.98 (d, 18H, $^2J_{\text{HP}} = 9.8$ Hz, $\text{P}(\text{CH}_3)_3$), 1.22 (d, 18H, $^2J_{\text{HP}} = 13.4$ Hz, $\text{P}(\text{CH}_3)_3$), 8.93 (d, 1H, $^4J_{\text{HtransP}} = 4.9$ Hz, O_2CH). $^{31}\text{P}\{^1\text{H}\}$ NMR (C_6D_6 , 162 MHz): δ -13.2 (m, 1P, P trans to H), -0.8 (dd, 2P, $^2J_{\text{PP}} = 34.4$ Hz, $^2J_{\text{PP}} = 24.3$ Hz, mutually trans $\text{P}(\text{CH}_3)_3$ ligands), 19.5 (td, 1P, $^2J_{\text{PP}} = 34.4$ Hz, $^2J_{\text{PP}} = 18.2$ Hz, P trans to O_2CH). Further evidence for the structure assignment was obtained by noting the close similarity of the ^1H NMR (hydride region) and $^{31}\text{P}\{^1\text{H}\}$ NMR spectra with those of the known complex *cis*- $\text{RuH}(\text{OC}_6\text{H}_4\text{-}p\text{-CH}_3)[\text{P}(\text{CH}_3)_3]_4$.⁵⁷

Results

Observations of Phase Behavior. Reactions in SCFs are strongly affected by phase changes. Although the phase behavior of pure CO_2 (Figure 2, top row) is known,^{1b} that of the multicomponent systems described here has not been published. For this reason, under conditions relevant to all reactions, the number of phases present was determined by visual observation of the CO_2/H_2 /additive mixture in a 50-mL steel vessel equipped with sapphire windows (Figures 2 and 3). The results are summarized below, and the case of $\text{N}(\text{C}_2\text{H}_5)_3$ at 50 $^\circ\text{C}$ is illustrated in Figure 4.

In the presence of only H_2 (80 atm, 50 $^\circ\text{C}$; Figure 4a), 20 mL of $\text{N}(\text{C}_2\text{H}_5)_3$ forms a liquid phase of approximately the same volume as the originally charged amine; the gas phase contains only a small concentration of the amine, as determined by chromatographic testing. In the presence of only CO_2 , the liquid phase expands to 24 mL at 30 atm or 34 mL at 60 atm (Figure 4b). This swelling of the liquid phase must be a result of dissolution of considerable amounts of CO_2 into that phase (Figure 2, middle row). At pressures above 80 atm, 20 mL of $\text{N}(\text{C}_2\text{H}_5)_3$ is completely miscible with scCO_2 in the absence of H_2 in a 50-mL vessel at 50 $^\circ\text{C}$ (Figure 4c). Visual inspection showed the existence of a single phase, while chromatographic testing of the uppermost regions of the reactor interior confirmed complete dissolution of the amine.

In the presence of both H_2 (85 atm) and CO_2 (total pressure 210 atm) at the same temperature, the situation is dramatically different. With amounts of $\text{N}(\text{C}_2\text{H}_5)_3$ below or equal to ~ 4 mL (29 mmol), only a single phase is visible (Figure 4d), although for amounts between 2 and 4 mL waviness is observed, indicating the existence of a density gradient (Figure 4e). The

(57) Osakada, K.; Ohshiro, K.; Yamamoto, A. *Organometallics* **1991**, *10*, 404–410.

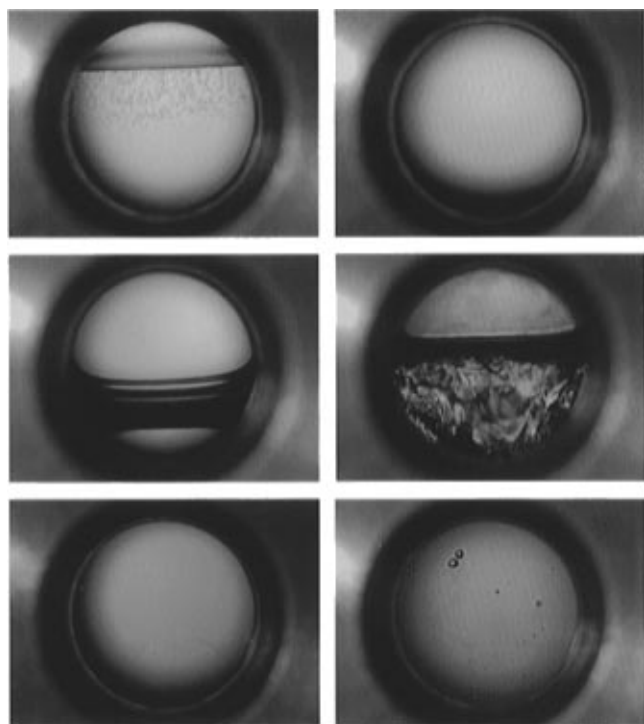

Figure 2. Photographs showing the interior of the window-equipped reactor vessel (see Figure 3) under various conditions: (top left) gently boiling liquid (lower phase) and gaseous (upper phase) CO_2 at 30 °C, (top right) scCO_2 (32 °C), (middle left) $\text{N}(\text{C}_2\text{H}_5)_3$ (14 mL) under 1 atm of CO_2 gas, (middle right) the same amount of amine under increasing pressure of CO_2 , showing the turbulence and the increase in volume of the liquid phase due to dissolution of CO_2 into the liquid amine, (bottom left) single-phase reaction mixture of H_2 (85 atm), $\text{N}(\text{C}_2\text{H}_5)_3$ (5 mmol), H_2O (0.1 mmol), and **3** (3 μmol) in scCO_2 (total 216 atm) at 50 °C just after the start of the reaction, and (bottom right) the same reaction mixture after the reaction is complete. The drops are liquid $\text{HCO}_2\text{H}/\text{N}(\text{C}_2\text{H}_5)_3$ adduct, the bulk of which rests at the bottom of the reactor and is not visible in the photograph.

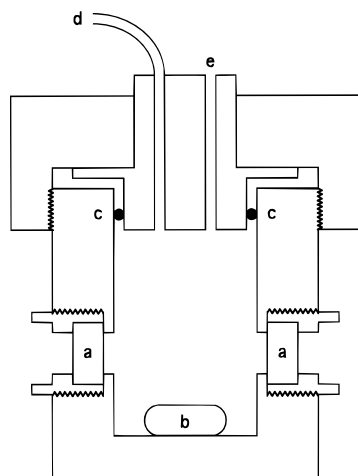

Figure 3. Cutaway drawing of the 50-mL window-equipped reaction vessel, showing (a) sapphire windows, (b) stir bar, (c) seal, (d) inlet/outlet for gases, and (e) inlet for liquid reagents, usually plugged. The other 50-mL vessels are similar except that they lack the window assemblies. Photographs taken through windows “a” are shown in Figure 2.

density gradients can be eliminated by vertical shaking but not by horizontal stirring alone. Amounts of $\text{N}(\text{C}_2\text{H}_5)_3$ above 4 mL cause the formation of two phases, the lower of which is always considerably larger in volume than the charged amine. For example, with 20 mL of $\text{N}(\text{C}_2\text{H}_5)_3$, the volume of the lower phase is 40 mL, suggesting that both amine and CO_2 are in that phase (Figure 4f). With 5 mL of amine, the lower phase is 17

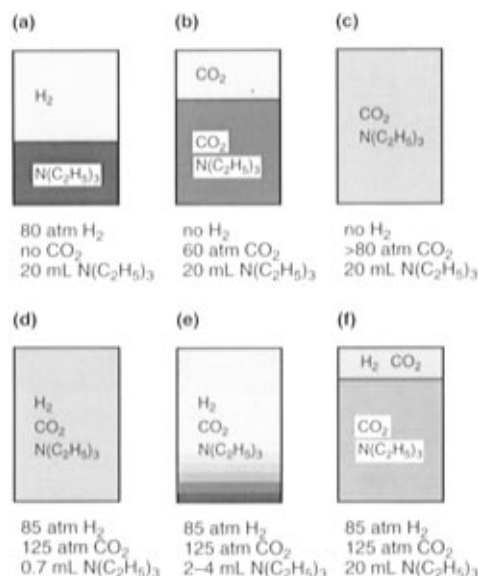

Figure 4. Schematic illustration of the phase behavior of the $\text{CO}_2/\text{H}_2/\text{N}(\text{C}_2\text{H}_5)_3$ system in a 50-mL reaction vessel at 50 °C, showing the major components of each phase and the relative volumes.

mL. Chromatographic testing of the upper gaslike phase shows that it contains very little amine. Thus, H_2 and possibly CO_2 are the major components of this phase. It is likely that the large amount of CO_2 in the lower phase increases the solubility of H_2 in that phase relative to the solubility of H_2 in liquid amine alone.

Similar observations were made with THF (15 mL), CH_3CN (15 mL), CH_3OH (10 mL), and DMSO (0.5 mL), all at 50 °C, CH_3OH (10 mL) at 80 °C, and THF (10 mL) at 100 °C. In each case two phases are clearly observed and the volume of the lower phase is significantly larger than the amount of liquid solvent added, suggesting that a large amount of CO_2 is present in the lower phase. Only with water (10 mL) is the volume of the lower phase equal to the volume of water added, suggesting that the amount of CO_2 dissolved in the water is small.^{58,59}

Homogeneous Hydrogenation of scCO_2 to Formic Acid.

The hydrogenation of scCO_2 to formic acid proceeds rapidly with the use of trimethylphosphine complexes of ruthenium(II) as catalyst precursors (Table 1). In a typical reaction, $\text{N}(\text{C}_2\text{H}_5)_3$ (5.0 mmol), the catalyst precursor (3 μmol), and water (0.1 mmol) were kept at 50 °C in a supercritical mixture of H_2 (85 atm) and CO_2 (total pressure 200–210 atm). At the start of the reaction only one phase is present (Figure 2, bottom left), but as the reaction proceeds, the liquid product, an adduct of $\text{N}(\text{C}_2\text{H}_5)_3$ and HCO_2H , precipitates (Figure 2, bottom right). Table 1 summarizes the results of the catalyst screening, indicating the AAR, the yield of formic acid, the TON, and the rate expressed in terms of the turnover frequency (TOF = turnovers/h = mol of product/mol of catalyst/h).

The most active of the catalyst precursors tested in scCO_2 are $\text{RuH}_2[\text{P}(\text{CH}_3)_3]_4$ (**1**), $\text{RuCl}_2[\text{P}(\text{CH}_3)_3]_4$ (**2**), and $\text{RuCl}(\text{O}_2\text{-CCH}_3)[\text{P}(\text{CH}_3)_3]_4$ (**3**). Reactions catalyzed by **1** and **3** do not

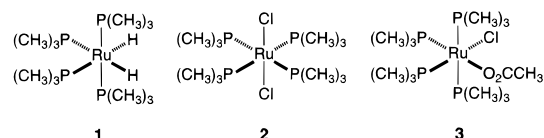

exhibit an induction period. With **1**, the reaction is fastest in

(58) Takenouchi and Kennedy⁵⁹ showed that the maximum concentration of CO_2 in liquid water at 100 bars is ≤ 1.4 mol % and varies little with temperature over the temperature range tested (110–350 °C).

(59) Takenouchi, S.; Kennedy, G. C. *Am. J. Sci.* **1964**, 262, 1055–1074.

Table 1. Effect of Catalyst Precursor on Yield and Rate of Hydrogenation of scCO_2^a

catalyst precursor	additive ^b	catalyst (μmol)	time (h)	yield (mmol)	AAR ^c	TON ^d	TOF ^e (h^{-1})
$\text{RuH}_2[\text{P}(\text{C}_6\text{H}_5)_3]_4$	H_2O	2.8	1	0.22	0.044	80	80
$\text{RuH}_2[\text{P}(\text{C}_6\text{H}_5)_3]_4$	CH_3OH	4.5	0.5	3.5	0.69	770	1500
$\text{RuH}_2[\text{P}(\text{CH}_3)_3]_4$ (1)	H_2O	2.2	1	3.0	0.60	1400	1400
$\text{RuH}_2[\text{P}(\text{CH}_3)_3]_4$ (1)	H_2O	3.2	3	6.0	1.2	1900	630
$\text{RuH}_2[\text{P}(\text{CH}_3)_3]_4$ (1)	CH_3OH	3.4	0.5	2.6	0.51	760	1500
$\text{RuCl}_2[\text{P}(\text{CH}_3)_3]_4$ (2)	H_2O	2.7	1	0.63	0.13	230	230
$\text{RuCl}_2[\text{P}(\text{CH}_3)_3]_4$ (2)	H_2O	3.2	16	8.1	1.6	2600	160
$\text{RuCl}(\text{O}_2\text{CCH}_3)[\text{P}(\text{CH}_3)_3]_4$ (3)	H_2O	3.4	1	3.6	0.72	1100	1100
<i>trans</i> - $\text{RuCl}_2(\text{dmpe})_2^f$	H_2O	3.2	5	0	0	0	0
<i>trans</i> - $\text{RuHCl}(\text{dmpe})_2^f$	H_2O	1.8	15	0.42	0.08	230	15
$\text{Ru}_3(\text{CO})_{12}$	H_2O	10	17	0.14	0.029	14	0.8
Pd/C	H_2O	10 ^g	143	0.9	0.18		

^a Conditions: 50 °C, 80–85 atm of H_2 , total pressure 200–210 atm, 50-mL reaction vessel, 5.0 mmol of $\text{N}(\text{C}_2\text{H}_5)_3$. Data rounded to two significant figures. ^b Additive = 0.1 mmol of water (single-phase system) or 250 mmol of CH_3OH (two-phase system). ^c Formic acid to amine mole ratio. ^d Turnover number = mol of product (formic acid)/mol of catalyst. TON is a unitless parameter. ^e Turnover frequency = TON/h. Units are h^{-1} . ^f dmpe = $(\text{CH}_3)_2\text{PCH}_2\text{CH}_2\text{P}(\text{CH}_3)_2$. ^g 31 mg of Pd/C, 10 wt % Pd.

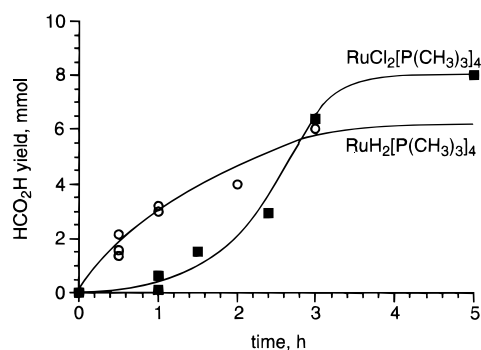

Figure 5. Dependence of formic acid yield on reaction time. Conditions: 85 atm of H_2 , total pressure 200–210 atm, 50 °C, 5.0 mmol of $\text{N}(\text{C}_2\text{H}_5)_3$, 2.5–3.2 μmol of Ru catalyst, 0.1 mmol of H_2O .

the first hour, with a TOF of 1400 h^{-1} , dropping to one-half this rate in the second hour (Figure 5). After the third hour, no further increase in yield is observed. On the other hand, the reactions catalyzed by **2** exhibit an induction period of ca. 1 h during which the yellow color of the catalyst disappears. The TOF in the subsequent 2 h is over 1000 h^{-1} . After 5 h, the hydrogenation catalyzed by **2** is complete, as indicated by an AAR ratio of 1.6–1.7.

As the reaction proceeds, the conditions change from basic (AAR < 1) to acidic (AAR > 1). The yield of formic acid obtained with **1** is lower than with **2**, with AAR values of up to 1.2 for the former catalyst, far below the values of 1.6–1.7 obtained with **2**. This could be due to catalyst instability in the acidic conditions present after AAR reaches 1.0. To test this possibility, experiments were performed in which formic acid (0.9 AAR) was added before the start of the reaction. The AAR climbed to 1.6 with catalyst **1** or 1.7 with catalyst **2** within 4 h. This demonstrates that both catalyst precursors still have activity even in the acidic conditions present at AAR > 1.

The other catalyst precursors tested were inferior in activity. Gray material was found on the walls of the reactor after a Rh catalyst precursor, $[\text{RhCl}(\text{nbd})_2]/(c\text{-C}_6\text{H}_{11})_2\text{PCH}_2\text{CH}_2\text{P}(c\text{-C}_6\text{H}_{11})_2$, was tested. The scCO_2 -soluble catalyst precursors $\text{Ru}_3(\text{CO})_{12}$ and *trans*- $\text{RuHCl}(\text{dmpe})_2$ and the heterogeneous catalyst Pd/C have low activity, while soluble *trans*- $\text{RuCl}_2(\text{dmpe})_2$ is completely inactive.

The solubility of Ru complex **2** was demonstrated qualitatively by passing a scCO_2 solution of the complex through a fine filter and a back-pressure regulator at 50 °C and 120 atm and collecting the solid which precipitated at the vent. The ^1H NMR spectrum of the collected material was identical with that of the starting material.

In scCO_2 , catalyst precursor **1** is far more active than $\text{RuH}_2[\text{P}(\text{C}_6\text{H}_5)_3]_4$, although in liquid CH_3OH the two catalyst

Table 2. Effect of the Base on the Yield of Hydrogenation of scCO_2^a

base	base (mmol)	catalyst (μmol)	time (h)	yield (mmol)	AAR	TON
none	0	13.2	13	0		0
K_2CO_3	2.5	9.0	16	1.2		140
KOH	5.4	2.9	15	0.75		260
$[\text{NH}_4][\text{O}_2\text{CNH}_2]$	2.4	2.5	15	0.099	0.021	39
$\text{N}(\text{C}_2\text{H}_5)_3$	5.0	3.2	16	8.1	1.6	2600
$\text{N}(\text{C}_2\text{H}_5)_3$	10.0	2.7	20	12.0	1.2	4400
$\text{N}(\text{C}_2\text{H}_5)_3$	30.2 ^b	3.2	84	18.9	0.63	6000
$\text{N}(\text{C}_2\text{H}_5)_3$	40.3 ^b	3.4	47	24.4	0.63	7200

^a Conditions: 50 °C, 50-mL reaction vessel, 80–85 atm of H_2 , total pressure 200–210 atm, catalyst precursor **2**, 0.1 mmol of water. ^b In a 150-mL reaction vessel at 220 atm of total pressure.

precursors have equal activity (Table 1). This suggests that the difference in activity between the two complexes in scCO_2 is a result of differing solubilities rather than electronic or steric effects.

Because of the nature of the equipment, we were not able to rule out the possibility that the catalyst decomposed to form some catalytically active solids. Blank tests without catalyst were performed repeatedly throughout the study to confirm that the reactor walls or any species thereon were not catalytically active.

Effect of the Base. The presence of a base is crucial for favorable thermodynamics.²⁸ In the supercritical system, the yield of formic acid is high in the presence of $\text{N}(\text{C}_2\text{H}_5)_3$, while in the absence of base, no formic acid is obtained (Table 2). Use of the solid bases K_2CO_3 , KOH, or $[\text{NH}_4][\text{O}_2\text{CNH}_2]$ also allows production of formic acid, albeit with low yields. A combination of $\text{N}(\text{C}_2\text{H}_5)_3$ and KOH is no more effective than the same amount of amine alone. The amine acts as a sink for the acid and is saturated at an AAR of ~ 1.7 , the highest AAR value observed in this system. Leitner et al.²⁹ observed 1.6–1.8 in DMSO and about 1.0 in water.³¹ The ratios in nonprotic solvents are higher than 1 because carboxylic acids and $\text{N}(\text{C}_2\text{H}_5)_3$ form stable 2:1 adducts, **4**, in nonprotic solvents or in the absence of any solvent.^{60,61}

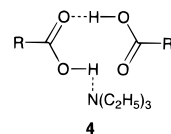

The amount of $\text{N}(\text{C}_2\text{H}_5)_3$ added has a strong effect on the rate of reaction. In the 50-mL vessel, the optimum amount of

(60) Barrow, G. M.; Yerger, E. A. *J. Am. Chem. Soc.* **1954**, *76*, 5211–5216.

(61) Wagner, K. *Angew. Chem., Int. Ed. Engl.* **1970**, *9*, 50–54.

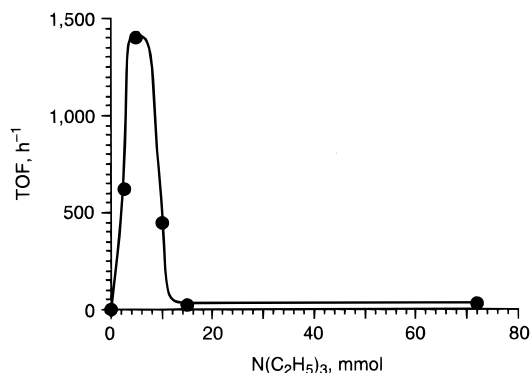
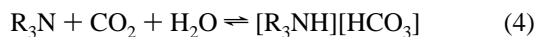

Figure 6. Effect of the amount of $\text{N}(\text{C}_2\text{H}_5)_3$ on the initial rate of formic acid production as measured during the first 0.5 or 1 h. Conditions: 50 °C, 3 μmol of $\text{RuH}_2[\text{P}(\text{CH}_3)_3]_4$ (**1**), 0.1 mmol of H_2O , 85 atm of H_2 , total pressure 200–210 atm.

$\text{N}(\text{C}_2\text{H}_5)_3$ is 5.0 mmol (Figure 6). The rate at 15.0 mmol of amine, in the region of density gradients but below the solubility limit (~ 30 mmol), is 60 times lower than with 5.0 mmol and is almost as low as the rate obtained in liquid amine (72 mmol) under otherwise identical conditions. Vertical shaking during the reaction time, which eliminates the density gradients, does not affect the rate. It is clear that the rate of the reaction can be affected not only by the kinetic dependence on amine concentration but also by phase behavior considerations. For example, if the system is close to the mixture critical point at 5.0 mmol of amine, then a favorable clustering effect⁶² could be the explanation for the high rate at that concentration. Because the phase behaviors of this $\text{CO}_2/\text{H}_2/\text{N}(\text{C}_2\text{H}_5)_3$ three-component mixture and the $\text{CO}_2/\text{H}_2/\text{N}(\text{C}_2\text{H}_5)_3/\text{HCO}_2\text{H}$ four-component mixture have not been mapped, only speculation is possible. Increasing the amount of amine and switching to a proportionately larger reactor allow increased yields of up to 7200 TON, although with reduced AAR values.

Effect of Water and Other Additives. The rate of the hydrogenation is improved by the addition of promoting additives. These additives can be used either in small amounts so that they can dissolve entirely in the scCO_2 phase or in large amounts so that they will cause the formation of a second phase. The initial rate was determined by measuring the yield after short reaction times with Ru complex **1** and a variety of additives (Table 3).

In the absence of any promoter other than **1** and the amine, the initial turnover frequency of formic acid production is 680 h^{-1} at 50 °C. With water as an additive (0.1 mmol, completely dissolved in scCO_2), the rate increases to 1400 h^{-1} . However, with 10 mL (560 mmol) of added water, a second (aqueous) phase forms and the rate drops to 34 h^{-1} . The slow rate of the CO_2 hydrogenation in the presence of liquid water was unexpected because the catalyst should not dissolve in that phase. A possible reason for the low rate could be reaction of the water with CO_2 and amine to form carbonates which would render the amine insoluble in scCO_2 and soluble in water (eq 4).



Attempts at using bases insoluble in scCO_2 have yielded unsatisfactory results (Table 2); a scCO_2 -dissolved base is preferred.

(62) Combes, J. R.; Johnston, K. P.; O'Shea, K. E.; Fox, M. A. In *Supercritical Fluid Technology: Theoretical and Applied Approaches to Analytical Chemistry*; Bright, F. V., McNally, M. E. P., Eds.; ACS Symposium Series 488; American Chemical Society: Washington, DC, 1992; pp 31–47.

With CH_3OH as the promoter, as with water, the rate is greater if only a single phase is present (>4000 h^{-1}) than if enough CH_3OH is used to form a second phase (1500 h^{-1}). However, it is important to note that the second phase formed is actually a mixture of CH_3OH and CO_2 . Depending on the compositions and properties of the phases, it could be that this lower phase is supercritical, rather than liquid, while the upper phase would be predominantly gaseous H_2 . For this reason, the term “two-phase system” may be more accurate than “liquid CH_3OH ”. The initial rate of the single-phase reaction with CH_3OH is too high to measure with the existing equipment;⁶³ the reaction is complete within 0.5 h. The initial rate must be greater than 4000 h^{-1} .

The trend of single-phase systems being faster than two-phase systems might also be true for the case of DMSO as the additive, but the reactions are too fast to measure.⁶³ Although the solubility of H_2 in pure DMSO is probably very low, the solubility of H_2 in the DMSO/ CO_2 mixture which exists under the reaction conditions could be considerably higher. The effectiveness of DMSO as a medium for subcritical CO_2 hydrogenation has been observed previously.^{32,33,64}

Reactions with two phases with THF or CH_3CN as the additive, even with water added as a promoter, have low rates of reaction. In fact, CH_3CN seemed to act as an inhibitor even when it did not form a second phase, possibly because it binds too strongly to the Ru center and impedes the catalytic cycle.

Other additives such as ethylenediamine, $\text{P}(\text{CH}_3)_3$, and carbon monoxide (Table 3) have an inhibiting effect on the reaction. However, a large amount (3.9 mmol) of $\text{P}(\text{CH}_3)_3$ was required in order to decrease the rate of reaction; use of only 39 μmol (20 equiv) had essentially no effect.

At 50 °C, the effect of additives on the total yield (Table 4) is not as dramatic as their effect on the rate. Slightly higher yields of formic acid are obtained in a $\text{scCO}_2/\text{CH}_3\text{OH}$ single-phase system (1.8 AAR) than in a $\text{scCO}_2/\text{CH}_3\text{OH}$ biphasic system (1.6 AAR) or $\text{scCO}_2/\text{H}_2\text{O}$ single-phase system (1.6 AAR). In contrast, the yield at 80 °C is highly dependent on the choice of additive, as will be described below.

Effect of H_2 Pressure on Yield. With a total pressure of 200–210 atm, the pressure of hydrogen was varied to determine the effect of this variable on the yield of overnight reactions catalyzed by **2** in a 50-mL reactor. Pressures of 60–85 atm give the optimum AAR values of 1.6–1.7. The yield of formic acid is independent of the amount of catalyst over a range of 3–10 μmol (at 85 atm, 5.0 mmol of amine), indicating that the reaction reaches equilibrium. At 34 atm of H_2 , however, a low yield is obtained (AAR = 0.3 after 18 h), while no formic acid is obtained in the absence of H_2 .

An attempt at the transfer hydrogenation of scCO_2 by 2-propanol (18 mmol of 2-propanol, 4.9 μmol of **1**, 5.0 mmol of $\text{N}(\text{C}_2\text{H}_5)_3$, 130 atm of CO_2 , no H_2 , 18 h, 50 °C) was not successful even though the reaction is enthalpically neutral (eq 5, B = amine base). Neither formic acid, propyl formate, nor acetone was detected in the reaction mixture. $\text{RuH}_2[\text{P}(\text{C}_6\text{H}_5)_3]_4$ is a known hydrogen transfer catalyst in other systems.⁶⁵

(63) Because these reactions are too fast, it was not possible to obtain reliable measurements of the true initial rate, even by using smaller amounts of catalyst.

(64) The observations that high yields of formic acid can be obtained in DMSO solution and that low yields are obtained at higher temperatures have been explained as an effect of entropy,³² although this is unlikely to be correct because in general the position of an equilibrium depends on enthalpy rather than entropy.

(65) Johnstone, R. A. W.; Wilby, A. H.; Entwistle, I. D. *Chem. Rev.* **1985**, 85, 129–170.

Table 3. Effect of Temperature, Water, and Other Additives on the Initial Rate of Hydrogenation of scCO_2^a

T ($^\circ\text{C}$)	additive (mmol)	water (mmol)	phases ^b	catalyst (μmol)	time (h)	yield (mmol)	AAR	TOF (h^{-1})
15		0.1	2	3.2	16	0.068	0.013	1.3
50		0	1	2.2	1	0.30	0.30	680
50		0.1	1	2.7	0.5	1.9	0.38	1400 ^c
50		0.1	1	2.2	1	3.0	0.60	1400
50		560	2	2.9	1	0.10	0.020	34
50	CO (1 atm)	0.1	1	2.5	0.5	0.059	0.012	48
50	$\text{P}(\text{CH}_3)_3$ (0.039)	0.1	1	1.9	0.5	1.3	0.25	1300
50	$\text{P}(\text{CH}_3)_3$ (39)	0.1	1	2.9	0.5	0.53	0.11	360
50	$\text{H}_2\text{N}(\text{CH}_2)_2\text{NH}_2$ (0.068)	0	<i>d</i>	3.4	0.6	0.32	0.065	190
50	THF (190) ^e	0.1	2	2.0	1	0.17	0.033	84
50	CH_3CN (6.7)	0.1	1	3.2	1	1.2	0.23	360
50	CH_3CN (290) ^e	0.1	2	3.2	1	1.1	0.21	330
50	CH_3OH (13)	0	1	2.5	0.5	5.0	1.0	>4000 ^f
50	CH_3OH (250) ^g	0	2	3.4	0.5	2.6	0.51	1500
50	DMSO (1.6)	0	1	2.9	0.5	4.9	0.97	>3300 ^f
50	DMSO (140) ^g	0	2	2.5	0.5	5.0	0.99	>4000 ^f
80		0.1	1	3.4	0.5	0.85	0.17	500
80	CH_3OH (13)	0	1	2.5	1	3.9	0.85	1600
80	CH_3OH (250) ^g	0	2	2.5	1	6.5	1.4	2600

^a Conditions: Ru complex **1**, 5.0 mmol of $\text{N}(\text{C}_2\text{H}_5)_3$, 80–85 atm of H_2 , total pressure 200–210 atm, 50-mL reaction vessel. ^b Number of phases visible at the start of the reaction. ^c Average of two runs. ^d Phase behavior not determined. ^e 15 mL. ^f Reactions with AAR = 1 are essentially complete; thus the initial rate must be higher than the rate shown.⁵⁵ ^g 10 mL.

Table 4. Production of Formic Acid and Methyl Formate at Various Temperatures in scCO_2^a

T ($^\circ\text{C}$)	additive	additive (mmol)	$\text{N}(\text{C}_2\text{H}_5)_3$ (mmol)	time (h)	AAR	TON	
						HCO_2H	HCO_2CH_3
50	H_2O	0.1	5.0	16	1.6	2600	0
50	CH_3OH	13	5.0	15	1.8	3300	150
50	CH_3OH	250	5.0	15	1.6	2900	100
50	CH_3OH	80 ^b	30 ^b	60	0.70	6700	270
80	H_2O	0.1	5.0	15	0.04	61	0
80	CH_3OH	13	5.0	1	0.22	360	0
80	CH_3OH^c	13	5.0	16	0.89	1100	330
80	CH_3OH	80 ^b	30 ^b	64	0.66	6800	3500
80	CH_3OH	250	5.0	1	1.1	2100	8
80	CH_3OH	250	5.0	19	1.2	2200	890
100	CH_3OH	13	5.0	16	0.17	250	150

^a Conditions: 50-mL reaction vessel, no water added except where indicated, 2.5–3.5 μmol of Ru complex **2**, 80–85 atm of H_2 , total pressure 200–210 atm. ^b In a 300-mL reaction vessel. ^c 4.2 μmol of **2**.

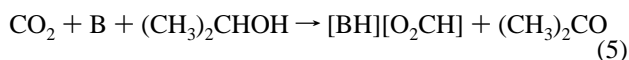

Effect of Temperature. The greatest rate of reaction with catalyst **1** and H_2O as promoter was observed at 50 $^\circ\text{C}$. The rates were calculated from the yield of formic acid after reactions of short duration, usually 0.5 h. The results (Figure 7) show that at temperatures lower than 50 $^\circ\text{C}$, the rate is very low. Pretreatment of the catalyst precursor with H_2 at 50 $^\circ\text{C}$ did not increase the rate of the reaction at 40 $^\circ\text{C}$. Visual inspection of a mixture of $\text{N}(\text{C}_2\text{H}_5)_3$ (0.7 mL, 5.0 mmol), CO_2 (120 atm), and H_2 (80 atm) showed density gradients at temperatures below about 45 $^\circ\text{C}$ but not a defined second phase. While it is normal for a reaction rate to decrease with decreasing temperature, the steepness of the observed drop in rate suggests that phase behavior rather than reaction kinetics is responsible. At 15 $^\circ\text{C}$ the rate is extremely slow, probably due to the phase separation which exists at this temperature. Above 50 $^\circ\text{C}$, the rate decreases with increasing temperature. Note that at these higher temperatures, the yield after 15–16 h also drastically decreases with temperature (Table 4). For example, the final yield of formic acid obtained after 15–16-h reactions with catalyst precursor **2** and H_2O as promoter is 8.1 mmol (AAR = 1.6) at 50 $^\circ\text{C}$ but only 0.17 mmol (AAR = 0.04) at 80 $^\circ\text{C}$. Addition of methanol to the system at higher temperatures greatly increases both the rate and the final yield (Tables 3 and 4) to the extent that the reaction is far too fast to determine the initial

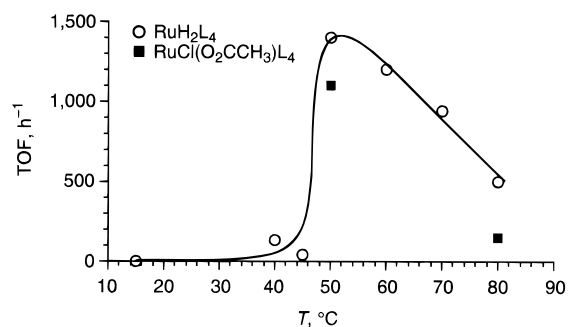
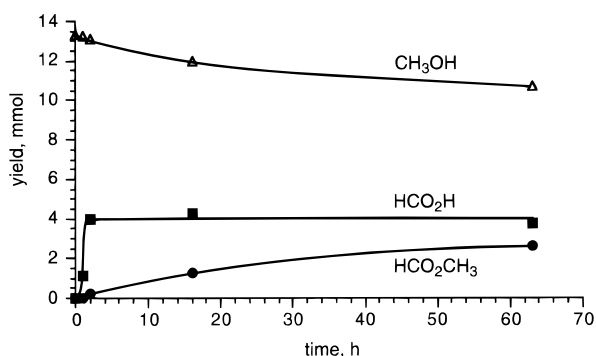
**Figure 7.** Temperature dependence of the rate of formic acid production. Conditions: 5.0 mmol of $\text{N}(\text{C}_2\text{H}_5)_3$, 3 μmol of catalyst ($\text{L} = \text{P}(\text{CH}_3)_3$), 0.1 mmol of H_2O , 85 atm of H_2 , total pressure 200–210 atm, 0.5 or 1 h.**Figure 8.** Time dependence of the product yields after reactions at 80 $^\circ\text{C}$ in a 50-mL reaction vessel with 80 atm of H_2 , 130 atm of CO_2 , 5.0 mmol of $\text{N}(\text{C}_2\text{H}_5)_3$, 3–4 μmol of **2**, and 13 mmol of CH_3OH .¹⁸

rates of formic acid production. In contrast, adding THF (5 mmol) does not increase the yield of the reaction (0.005 mmol of formic acid after 15 h at 80 $^\circ\text{C}$).

Production of Methyl Formate. The hydrogenation of scCO_2 in the presence of CH_3OH produces methyl formate in excellent yield in addition to formic acid (eq 2). The presence of a base such as $\text{N}(\text{C}_2\text{H}_5)_3$ is again necessary. During the reaction with catalyst **2** at 80 $^\circ\text{C}$, after an induction period of about 1 h, formic acid is produced rapidly. The concentration of formic acid reaches an equilibrium value of 0.80–0.89 mol/mol of the amine by the end of the second hour (Figure 8). The amount of formic acid is constant after this time. Methyl formate is produced more slowly. These results clearly show

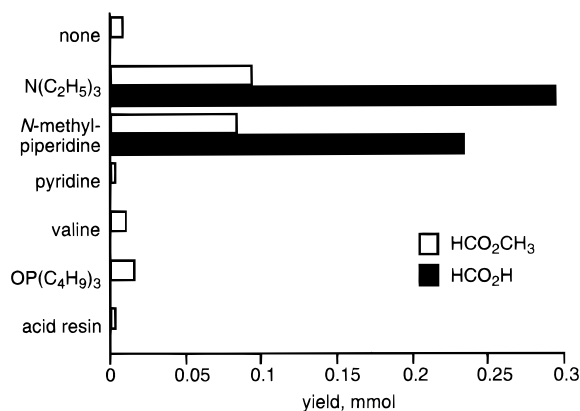

Figure 9. Effect of the choice of base on the yield of formic acid and methyl formate. Conditions: 0.72 mmol of base, 13 mmol of CH₃OH, 3–5 μmol of **2**, 80 °C, 16 h.

that methyl formate is synthesized in a two-step pathway: Ru-catalyzed hydrogenation of scCO₂ to formic acid (eq 1) followed by thermal esterification to methyl formate (eq 6).



The maximum yield of methyl formate is obtained at ca. 80 °C due to slow thermal esterification at lower temperatures and low catalytic activity for hydrogenation at higher temperatures.¹⁸

Increasing the amount of CH₃OH causes a second phase to form. The yields of formic acid and methyl formate and, to a lesser extent, the selectivity increase (Table 4). Decreasing the amount of CH₃OH added to the reaction causes dramatically decreasing yields of both formic acid and methyl formate. Against expectations, however, the selectivity for methyl formate increases.¹⁸

Base is added to increase the yield of the formic acid in the hydrogenation step, but the tests described below show that base inhibits the subsequent thermal esterification. Thus the role of base is critical to the yield and selectivity for formate ester (Figure 9). Reducing the amount of amine and keeping the concentration of alcohol constant does not increase the selectivity for the ester but only decreases the final yield.¹⁸ Substituting *N*-methylpiperidine for N(C₂H₅)₃ has little effect on the yield or selectivity. With weak bases or in the absence of any base, very low yields of methyl formate are produced with complete selectivity. In the absence of base and with catalyst **1**, no methyl formate is obtained.

Normally, esterification of carboxylic acids by alcohols is catalyzed by an acid. However, this synthesis of methyl formate requires an uncatalyzed thermal esterification in the presence of an excess of base, a process which is not used in organic chemistry. To confirm that the reaction can proceed in the presence of base, formic acid (4 mmol), CH₃OH (13 mmol), and N(C₂H₅)₃ (5 mmol) were heated to 80 °C in a closed vessel under argon. After 15 h, 7% of the acid had been esterified to methyl formate. In order to determine the factors which influence esterification in basic solutions, we have tested the thermal esterification of CH₃OH and acetic acid under argon without solvent (eq 7, Table 5). Acetic acid was chosen because it is less volatile and more resistant to decomposition than formic acid.

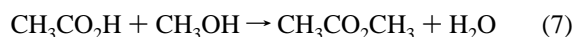

Triethylamine acts as an inhibitor, as expected, but even excess amine does not completely prevent esterification. In the absence of amine, acidic resins are catalysts for the esterification, increasing the conversion from 88% to 100%. In the presence of amine, however, the effectiveness of the acidic resins is

Table 5. Acetic Acid Thermal Esterification with Methanol in the Presence or Absence of Triethylamine^a

additive (g)	gas	esterification of acid (%)	
		with amine	without amine
	CO ₂	18	
	argon	25 ^b	88
pentane (0.6)	argon	28	
MS 3A (0.5)	argon	25	
Amberlyst (0.1)	argon	24	100
Nafion 511 (0.1)	argon	20	100

^a Conditions: 44 h, 100 °C, 5.0 mmol of CH₃CO₂H, 13 mmol of CH₃OH, either 5.0 or 0 mmol of N(C₂H₅)₃, 1 atm of argon or 150 atm of CO₂. MS 3A is a molecular sieve, while Amberlyst and Nafion 511 are acidic resins. ^b This value decreases to 16% in the presence of 10 mmol of amine.

Table 6. Production of Formamides from Amines and scCO₂^a

amine	amine (mmol)	catalyst (μmol)	time (h)	TON	
				amide	HCO ₂ H
NH(C ₆ H ₁₁) ₂	5.0	3.4	15	0	1400
NH(<i>i</i> -C ₃ H ₇) ₂	5.0	2.3	23	0	1600
NH(C ₂ H ₅) ₂	5.0	2.3	13	820	950
NH ₂ (<i>n</i> -C ₃ H ₇)	5.0	3.4	5	260	620
NH(CH ₃) ₂	7.5	2.9	5	2100	190
NH(CH ₃) ₂	7.5	3.8	15	1500	0
NH(CH ₃) ₂	25.6 ^b	2.5	22	9900 ^b	0

^a Conditions: catalyst precursor **2**, 80 atm of H₂, 130 atm of CO₂, 100 °C, 50-mL reaction vessel. ^b 150-mL reaction vessel.

completely eliminated. Molecular sieves are also ineffective in the presence of amine. The conversion to ester is slightly lower in scCO₂ than under argon.

The esterification of formic acid (eq 6) is reversible. An equimolar mixture of methyl formate and water heated to 100 °C for 28 h under argon and in the absence of any catalyst gives 7% conversion to formic acid and CH₃OH. In the presence of catalyst precursor **2**, the same amount of CH₃OH is observed, but formic acid is not observed, presumably due to catalyzed decomposition of the formic acid to CO₂ and H₂. These results suggest that improved selectivity for ester formation could be achieved by effective removal of the water.

Production of Formamides from Primary or Secondary Amines. In the presence of diethylamine, dimethylamine, or *n*-propylamine instead of N(C₂H₅)₃, the hydrogenation of scCO₂ with catalyst **2** at 100 °C produces *N*-substituted formamides (eq 3) instead of or in addition to the ammonium formate salts (Table 6). In the case of dimethylamine, 99% conversion to and selectivity for DMF can be obtained. Bulky dialkylamines such as dicyclohexylamine and diisopropylamine produce only ammonium formate salts, which suggests that the rate of dehydration of such salts to the corresponding formamides is strongly influenced by steric factors. Surprisingly, ammonia, introduced as the carbamate (Table 7), gave only low conversion to the formamide, although the reason for its poor reactivity is more likely to be its poor solubility in scCO₂. A byproduct from the reaction of NH(CH₃)₂ was detected as a singlet in the ¹H NMR spectrum with a chemical shift identical with that of N(CH₃)₃. Yields of this product ranged up to 2 mol % but were usually negligible.

Dialkylamines react reversibly with CO₂ to form dialkylammonium dialkylcarbamates (eqs 8 and 9).^{56,66–68}

(66) Wright, H. B.; Moore, M. B. *J. Am. Chem. Soc.* **1948**, *70*, 3865–3866.

(67) Fields, S. M.; Grolimund, K. *J. High Resolut. Chromatogr., Chromatogr. Commun.* **1988**, *11*, 727–729.

(68) Takeshita, K.; Kitamoto, A. *J. Chem. Eng. Jpn.* **1988**, *21*, 411–417.

Table 7. Production of Formamides from Ammonium Carbamates, H₂, and scCO₂^a

amine	carbamate (mmol)	reactor vol (mL)	P _{H₂} (atm)	P _{CO₂} (atm)	time (h)	TON	
						amide	HCO ₂ H
NH ₃	5	50	80	130	20	500	1700
NH ₂ CH ₃	5	50	80	130	12	1800	20
NH ₂ CH ₂ CH ₃	5	50	80	130	15	2000	410
NH(CH ₃) ₂	5	50	80	130	0.5	820	2300
NH(CH ₃) ₂	5	50	80	130	4	2600	250
NH(CH ₃) ₂	5	50	80 ^b	130	4 ^b	76	4
NH(CH ₃) ₂	5	50	80	130	14	2800	90
NH(CH ₃) ₂	31	150	80	130	22	25 000	280
NH(CH ₃) ₂	79	150	80	130	19	62 000	680
NH(CH ₃) ₂	210	150	80	130	18	150 000	4000
NH(CH ₃) ₂	1900	300	80 ^c	130 ^c	70	420 000	0
NH(CH ₃) ₂	5	50	86	57	1	1000	1600
NH(CH ₃) ₂	5	50	50	0	3	320	160

^a Conditions: 2–3 μmol of catalyst **2** amines or ammonia charged as the carbamate, 100 °C. ^b 1 atm of CO also present. ^c Extra H₂ and CO₂ added several times during the reaction.



These reactions have a number of consequences for the formamide synthesis. The solubility of nonbulky primary and secondary alkylamines in CO₂ is low⁶⁷ because of carbamate formation.^{66,68} Thus a liquid (R = CH₃) or solid (R ≠ CH₃) carbamate phase, [NH₂R₂][O₂CNR₂], is present from the start of the formamide synthesis. Tests at room temperature and pressure showed that the Ru catalyst is insoluble in the liquid carbamate salt. Thus, the initial reaction is believed to take place in the scCO₂ phase. We speculate that the catalyst remains in the supercritical phase throughout the reaction,¹⁷ which may be the reason for the high rate and yields (see below).

Gaseous amines such as NH(CH₃)₂ can be charged to the reactor more conveniently in the form of the liquid or solid carbamate salts, which can be handled at room temperature. DSC experiments under argon showed that the temperatures of the onset of decomposition for the solid carbamates of NH₃, NH₂CH₃, and NH₂CH₂CH₃ are 38, 52, and 48 °C, respectively. For the DMF synthesis, the use of dimethylammonium dimethylcarbamate is experimentally easier than the use of cooled liquid dimethylamine, although the same results are obtained by either method. In particular, the time profile shown in Figure 10 for reactions of dimethylammonium dimethylcarbamate is identical with that obtained with dimethylamine as the starting material. The results obtained with several carbamates are shown in Table 7.

By using the carbamate as the source of NH(CH₃)₂ and by using a large carbamate to catalyst ratio, an exceedingly high efficiency of conversion of H₂, CO₂, and NH(CH₃)₂ can be obtained. For example, with 79 mmol of carbamate (158 mmol of amine) in a 150-mL reactor, the catalytic efficiency was 62 000 TON with 99% conversion of the amine and 99% selectivity for DMF. If very large amounts of carbamate are used, H₂ becomes the limiting reagent. In order to avoid this problem and the related problem of dropping scCO₂ pressure, extra H₂ and CO₂ were periodically added during large scale reactions, although the H₂/CO₂ ratio could not be monitored. By this method, DMF was obtained with 420 000 TON (71% yield based on charged amine) in a 300-mL reactor. Noteworthy in this latter reaction was the absence of any formic acid among the products, despite the presence of unreacted amine. This suggests that the hydrogenation step slowed down late in the reaction and became the rate-determining step, probably because of insufficient H₂ or CO₂ pressure. With proper monitoring of the H₂/CO₂ partial pressures and controlled makeup gas, even

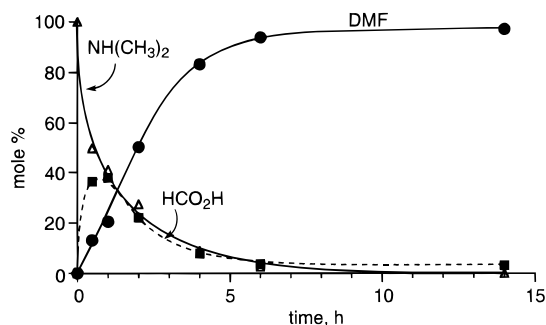
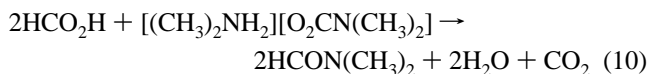

Figure 10. Composition of the product mixture as a function of reaction time during the synthesis of DMF from NH(CH₃)₂ (10 mmol, charged as the carbamate), 80 atm of H₂, and 130 atm of scCO₂ at 100 °C catalyzed by 2.5 μmol of **2**.

higher yields should be possible. The high yield reactions in Table 7 have overall rates⁶⁹ of up to 8000 h⁻¹.

By performing a series of reactions (5.0 mmol of dimethylammonium dimethylcarbamate) with varying reaction times, a profile of the reaction was obtained (Figure 10).¹⁷ The data show that formic acid is generated very quickly but reaches a maximum (6 mmol) at about 0.5 h, after which it declines to 0.2 mmol (3%). Under other conditions or with longer reaction times, the amount of formic acid remaining is lower or even undetectable. DMF is produced more slowly than formic acid but reaches 90% conversion by about 5 h. This reaction profile is consistent with the catalytic hydrogenation of scCO₂ to the dimethylammonium salt of formic acid followed by dehydration to DMF. Tests with formic acid and dimethylammonium dimethylcarbamate showed that the dehydration can be achieved at 100 °C without catalyst (eq 10). The reaction of 5 mmol each of formic acid and carbamate, formic acid being the limiting reagent, gave 100% conversion to DMF at 100 °C after 17 h under 3 or 130 atm of CO₂. The same reaction at 150 °C without solvent has been reported in the patent literature.⁵⁶



The reverse reaction, hydrolysis of DMF to dimethylammonium formate, was not observed under these conditions; DMF and water (10 mmol each) heated to 100 °C in the presence or absence of **3** did not react within 20 h. Therefore the conversion of CO₂, H₂, and NH(CH₃)₂ to DMF is irreversible under these conditions.

The initial rates of production of formic acid and DMF over the first hour at the conditions of Figure 10 are 2300 and 1300 h⁻¹, respectively. Addition of 10 mL of THF, which is too much to dissolve in the scCO₂/H₂ mixture, causes the initial rates to be reduced to 390 and 740 h⁻¹. The dramatic decrease in the rate of hydrogenation may indicate that the THF induced the catalyst to dissolve in the liquid phase.

In the absence of Ru catalyst, only trace amounts of formic acid and DMF are observed. Using no CO₂ except for that contained in the carbamate results in an extremely slow reaction. An atmosphere of CO strongly inhibits the DMF synthesis. The synthesis of DMF from scCO₂ also proceeds at the lower temperature of 75 °C, although the rate of the dehydration step is decreased (1500 mol of HCO₂H and 2400 mol of DMF per mol of **2** or 62% conversion of NH(CH₃)₂ to DMF after 5 h).

The use of 8 atm of D₂ gas and a reaction time of only 75 min produced DMF-*d*₁ in 3% conversion and 80% isotopic

(69) If the same rate were obtained in a flow system, the space-time yield would be 9 kg of DMF/g of Ru catalyst/L (reactor volume)/h. Because such figures are usually calculated from flow rather than batch reactions, this value should only be considered an indicator of high productivity.

purity. The mass spectrum of the product DMF suggests that the deuteron was at the formyl position rather than in a methyl group. An isolated single peak at 58 m/z (molecular ion minus CH_3) in DMF- d_0 was shifted to a single peak at 59 m/z in the spectrum of DMF- d_1 rather than to two peaks at 58 and 59 m/z , as would have been expected if the deuteron resided in the methyl groups.

Stoichiometric Reaction of $\text{RuH}_2[\text{P}(\text{CH}_3)_3]_4$ with CO_2 . Complex **1** in C_6D_6 is converted by CO_2 (1 min bubbling at 1 atm) in 9% yield to a monohydride complex with an NMR spectrum consistent with *cis*- $\text{RuH}(\text{O}_2\text{CH})[\text{P}(\text{CH}_3)_3]_4$. The extent of the conversion was unaffected by the presence or absence of 4 equiv of free $\text{P}(\text{CH}_3)_3$.

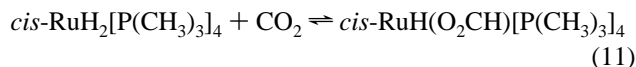

The ratio of *cis*- $\text{RuH}(\text{O}_2\text{CH})[\text{P}(\text{CH}_3)_3]_4$ to **1** was decreased by subsequent bubbling of H_2 for 1 min through the solution, presumably by the reverse of reaction 11. No formic acid was detected.

Insertion of CO_2 has been observed previously with the related complex *cis*- $\text{RuH}_2[\text{P}(\text{C}_6\text{H}_5)_3]_4$,^{70–72} although in that case CO_2 insertion was accompanied by phosphine dissociation, giving $\text{RuH}(\text{O}_2\text{CH})[\text{P}(\text{C}_6\text{H}_5)_3]_3$.

Discussion

Synthetic Utility of the Hydrogenation of scCO_2 . The homogeneous hydrogenation of CO_2 is rapid and efficient if the CO_2 is in the supercritical state. The yield of formic acid, in terms of TON or AAR, is excellent, and the selectivity for formic acid is 100%. The hydrogenation of scCO_2 in the presence of CH_3OH and $\text{N}(\text{C}_2\text{H}_5)_3$ catalyzed by **3** at 80 °C is also particularly efficient, with the highest yield of methyl formate being 3500 TON (Table 4). This is 1 order of magnitude greater than any previous result at any temperature.²⁸

Using the new supercritical method, we were also able to produce DMF with overall rates of up to 8000 h^{-1} and with TON values of up to 420 000. This TON exceeds by 2 orders of magnitude the highest previously reported value for the synthesis of DMF using CO_2 .^{28,44} Thermodynamically, the DMF synthesis is strongly favorable, and the dehydration step is irreversible under these conditions. However, only one of the previous studies succeeded in obtaining close to quantitative yields of DMF from $\text{NH}(\text{CH}_3)_2$ by this reaction, and that accomplishment required reaction temperatures of 150–170 °C.⁴⁵ By the new method we have obtained 99% conversion at the relatively low temperature of 100 °C. The advantage in the use of scCO_2 is particularly evident at short reaction times, when rapid synthesis of the formate salt is a prerequisite for prompt formation of DMF.

The high TON values obtained in the formic acid, methyl formate, and DMF syntheses do not necessarily demonstrate that the equilibria of these reactions have been shifted by the use of supercritical conditions. Rather, they demonstrate that the Ru catalysts have long lifetimes under these conditions and that the reaction rate is so rapid that very high TON can be attained within reasonable reaction times. Thus, high productivity could be obtained if these syntheses were applied in continuous flow reaction systems.

Reasons for the High Rate of Reaction in scCO_2 . Possibly the most important reason for the high rate obtained in scCO_2 is the complete miscibility¹⁵ of H_2 with scCO_2 compared to the low solubility of H_2 in most organic solvents.¹⁶ The miscibility of H_2 allows all of the CO_2 , H_2 , $\text{N}(\text{C}_2\text{H}_5)_3$, and catalyst to be in the same phase, which is not possible with subcritical conventional solvents. This strategy requires the designing of a catalyst which is highly soluble in scCO_2 ; this point will be discussed in further detail below. Less obvious in the present system but potentially as important to the high rate are other factors such as a weaker coordination sphere around the catalyst, rapid diffusion in the supercritical phase, and elimination of the problem of slow mass transfer between the gaseous and liquid phases.³

The solubilization of transition metal–phosphine complexes in scCO_2 is necessary if these ubiquitous and useful catalysts are to be employed in that medium. Transition metal complexes which have been demonstrated to be soluble in scCO_2 include those with carbonyl, cyclopentadienyl, porphyrin, acetylacetonate, and other chelating ligands but not, previous to our study, any with phosphine ligands. While the complexes $\text{RuH}_2[\text{P}(\text{C}_6\text{H}_5)_3]_4$ and $\text{RuCl}_2[\text{P}(\text{C}_6\text{H}_5)_3]_3$ are known to be active for CO_2 hydrogenation in organic liquids,^{73–75} we anticipated that they would have low solubility in nonpolar scCO_2 . To increase the solubility of the complexes in scCO_2 , the trimethylphosphine analogues were used. The success of this strategy is shown by the greater rate of the reaction catalyzed by **1** in scCO_2 compared to that by $\text{RuH}_2[\text{P}(\text{C}_6\text{H}_5)_3]_4$ (Table 1). The rate difference is not due to electronic differences; the trimethylphosphine and triphenylphosphine catalyst precursors have equal activity in liquid methanol (Table 3). The solubility test performed on the stable catalyst precursor **2** demonstrated conclusively that trimethylphosphine complexes are soluble in scCO_2 . Quantitative studies of the solubility of phosphines and their complexes would be of great value to the study of homogeneous catalysis and transition metal chemistry in scCO_2 .

Effect of Product Precipitation. The number of phases present during the reaction is not only a function of temperature, pressure, and the amounts of additives but also of the reaction time. Under the standard conditions used, only a single-phase exists at the start of the reaction (Figure 2, bottom left). Because the product, probably $[\text{NH}(\text{C}_2\text{H}_5)_3][\text{O}_2\text{CH}]\cdot\text{HCO}_2\text{H}$,^{60,61} precipitates from the scCO_2 over time, two phases exist during the later stages of the reaction (Figure 2, bottom right). In a window-equipped reactor vessel, the first visible signs of liquid formation come after 10 min at 50 °C with catalyst precursor **1**. The change from a single phase to two phases during the reaction could significantly alter the catalytic activity. For example, experiments with very large amine to catalyst ratios performed in a 300-mL reactor resulted in TON values of up to 7200 but AAR far lower than those found for the standard experiments, even though the reaction times were greater. This indicates that equilibrium is not reached, probably because the reaction is much slower under such conditions. It is possible that the reaction slows down because the catalyst dissolves in the liquid phase which builds up as the product precipitates. The rest of the reaction may take place in that phase, with the reduced rates associated with liquid phase reactions.

One of the functions of the CH_3OH or DMSO promoters may be as cosolvents acting to increase the solubility of the catalyst in the supercritical phase. This would be particularly important during the later stages of the reaction if the promoter were able

(70) Komiya, S.; Yamamoto, A. *J. Organomet. Chem.* **1972**, *46*, C58–C60.

(71) Kolomnikov, I. S.; Gusev, A. I.; Aleksandrov, G. G.; Lobeeva, T. S.; Struchkov, Yu. T.; Vol'pin, M. E. *J. Organomet. Chem.* **1973**, *59*, 349–351.

(72) Komiya, S.; Yamamoto, A. *Bull. Chem. Soc. Jpn.* **1976**, *49*, 784–787.

(73) Inoue, Y.; Izumida, H.; Sasaki, Y.; Hashimoto, H. *Chem. Lett.* **1976**, 863–864.

(74) Yamaji, T. Japan Kokai Tokyo Koho 140948, 1981.

(75) Drury, D. J.; Hamlin, J. E. Eur. Patent Appl. 0 095 321, 1983.

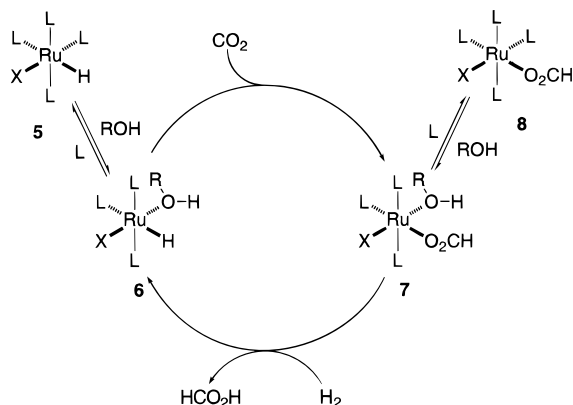

Figure 11. Possible mechanism of CO_2 hydrogenation ($X = \text{H}$ or Cl , $R = \text{H}$ or CH_3 , $L = \text{P}(\text{CH}_3)_3$).

to prevent or retard the dissolution of the catalyst in the liquid product phase.

Hydrogenation Mechanism. It is not possible with the present data to determine the mechanism of the CO_2 hydrogenation. However, there are some general comments which can be made.

Most mechanisms for the hydrogenation of CO_2 to formic acid require metal hydride active species.²⁸ Although catalyst precursors $\text{RuCl}_2[\text{P}(\text{CH}_3)_3]_4$ (**2**) and $\text{RuCl}(\text{O}_2\text{CCH}_3)[\text{P}(\text{CH}_3)_3]_4$ (**3**) do not contain hydride ligands, the conversion of these catalyst precursors to *cis*- $\text{RuHCl}[\text{P}(\text{CH}_3)_3]_4$ should be facile in the presence of H_2 and base.^{76,77} This process is likely the cause of the induction period when **2** is used as a catalyst precursor (Figure 5). The further conversion of *cis*- $\text{RuHCl}[\text{P}(\text{CH}_3)_3]_4$ to $\text{RuH}_2[\text{P}(\text{CH}_3)_3]_4$ (**1**) is possible. It is interesting to compare the catalytic activity of **2** to a similar dichloro complex which is unable to undergo the conversion to a chloro hydrido complex. For example, *trans*- $\text{RuCl}_2(\text{dmpe})_2$ can not be converted to a hydride complex by H_2 and base.⁷⁸ Without any hydride ligand, the complex can not undergo CO_2 insertion or catalyze CO_2 hydrogenation: The observed catalytic activity was zero. In contrast, the complex *trans*- $\text{RuHCl}(\text{dmpe})_2$ is catalytically active. These considerations demonstrate that a hydride ligand in the catalyst is a prerequisite for catalytic activity.

Several mechanisms for the catalytic hydrogenation of CO_2 by hydride catalysts have been suggested, most of these based on CO_2 insertion into the metal–hydride bond.²⁸ This reaction is known for the closely related complex $\text{RuH}_2[\text{P}(\text{C}_6\text{H}_5)_3]_4$ ^{70,71} and was also observed by us when that complex was dissolved in *scCO*₂ in the absence of amine and H_2 . In-situ NMR studies described in the Results showed that CO_2 insertion into the $\text{Ru}-\text{H}$ bond of complex **1** is also possible, giving $\text{RuH}(\text{O}_2\text{CH})[\text{P}(\text{CH}_3)_3]_4$ (eq 11). $\text{Ru}(\text{O}_2\text{CH})\text{Cl}[\text{P}(\text{CH}_3)_3]_4$ would be the active species formed from **2** or **3** via $\text{RuHCl}[\text{P}(\text{CH}_3)_3]_4$ and is expected to be as active as **3**.

Figure 11 illustrates a possible mechanism for the hydrogenation under the current reaction conditions, where water or alcohol is acting as a promoter. In this mechanism, a phosphine ligand in the Ru hydride **5** is replaced by ROH (alcohol or water) to generate the chain carrier **6**. Subsequent insertion of CO_2 into the $\text{Ru}-\text{H}$ bond occurs to give the formate complex **7**, which may be in equilibrium with $\text{RuX}(\text{O}_2\text{CH})[\text{P}(\text{CH}_3)_3]_4$ (**8**). The latter complex ($X = \text{H}$) was detected in stoichiometric tests, as mentioned above. Hydrogenolysis of the $\text{Ru}-\text{O}_2\text{CH}$ bond

in **7** (or **8**) by molecular hydrogen forms formic acid, regenerating the catalytic species **6**. Hydrogenolysis, conceivably the rate-determining step, would be considerably accelerated under the supercritical conditions because of the high concentration of H_2 .

It should be mentioned that the $\text{Ru}-\text{H}$ species may react directly with uncoordinated CO_2 with the aid of a metal-coordinated protic reagent.⁷⁹ Water has been shown to be necessary in amounts of at least 1 mol/mol of catalyst for reaction 1 catalyzed by a Pd -phosphine complex.⁷³ We have found that the use of water, CH_3OH , or DMSO as promoters causes an increase in rate over that in the absence of any such promoter (Table 3). The highest turnover rates, over 4000 h^{-1} , were obtained with CH_3OH or DMSO promoters. The effectiveness of DMSO may be at least partly a result of water dissolved therein. CH_3OH was also effective at 80°C , at which temperature the water-promoted reaction was inefficient. There are many mechanisms for CO_2 hydrogenation which could be consistent with a promoting effect of water or alcohol,²⁸ including the possibility⁷⁹ that the promoter binds to the metal and stabilizes the activated complex by hydrogen bonding during the CO_2 insertion. A possible transition state is illustrated by structure **9**.

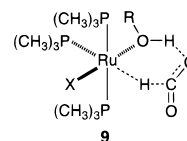

A vacant site made available by the dissociation of a phosphine ligand may be a prerequisite for the CO_2 insertion step or the subsequent hydrogenolysis step.⁷⁷ Although a few equivalents of added $\text{P}(\text{CH}_3)_3$ have no effect on the insertion of CO_2 into $\text{RuH}_2[\text{P}(\text{CH}_3)_3]_4$ or on the hydrogenation of *scCO*₂, a large excess of $\text{P}(\text{CH}_3)_3$ has an inhibiting effect on the catalytic hydrogenation, which is evidence for a rate-determining step that requires concomitant or prior phosphine dissociation. The same conclusion is suggested by the low rate of hydrogenation with *trans*- $\text{RuHCl}(\text{dmpe})_2$, which is attributed to the inability of the chelating diphosphine ligands to easily dissociate. The data mentioned above are consistent with but not proof of phosphine dissociation in the mechanism.⁸⁰

One of the alternative mechanisms for CO_2 hydrogenation,²⁸ the reverse water–gas shift reaction giving CO and H_2O followed by their recombination to produce formic acid, can clearly be rejected. CO was found to have a strong inhibiting effect on the reaction, which suggests that a reverse water–gas shift reaction does not occur to any significant extent during the hydrogenation of *scCO*₂ and that the reverse water–gas shift reaction does not form part of the catalytic cycle.

Measurement of the detailed kinetics of the reaction and in particular the effect of altered concentrations of CO_2 or H_2 on the rate of reaction would not necessarily lead to an unambiguous identification of the mechanism. Adjusting the amounts of the reagents has such a strong and at present unpredictable effect on the phase behavior that a proper kinetic study would be both difficult and inadvisable before the phase behavior is better understood.

Reaction Pathways to Alkyl Formates and Formamides.

The reaction profile for the methyl formate synthesis (Figure 8)¹⁸ is consistent with a two-step pathway of CO_2 hydrogenation

(76) Hallman, P. S.; McGarvey, B. R.; Wilkinson, G. J. *Chem. Soc. A* **1968**, 3143–3150.

(77) Jessop, P. G.; Morris, R. H. *Coord. Chem. Rev.* **1992**, *121*, 155–284.

(78) Bautista, M. T.; Cappellani, E. P.; Drouin, S. D.; Morris, R. H.; Schweitzer, C. T.; Sella, A.; Zubkowski, J. *J. Am. Chem. Soc.* **1991**, *113*, 4876–4887.

(79) Tsai, J.-C.; Nicholas, K. M. *J. Am. Chem. Soc.* **1992**, *114*, 5117–5124.

(80) Alternative explanations for the observations are possible: The large excess of phosphine could be acting as additional base, which would cause a decrease in the rate, and the poor activity of *trans*- $\text{RuHCl}(\text{dmpe})_2$ could be due to its *trans* geometry, which may not be favorable to CO_2 insertion.

(eq 1) followed by esterification (eq 6), a mechanism which has been proposed previously.^{39,40} The formic acid intermediate is observed in our system because the first step is very fast under these conditions. The second step, the esterification, is rate determining. There is a possibility that another mechanism not involving formic acid is responsible for the production of methyl formate. However, this is unlikely because independent tests confirmed that formic acid is thermally esterified by methanol under these conditions even in the presence of an amine.

Methanol is required not only as an esterification reagent in the second step but as a remarkably effective promoter of the hydrogenation step as well. The kinetic data at 50 and 80 °C clearly show significantly increased rates of formic acid production in the presence of CH₃OH.

The reaction profile¹⁷ of the DMF synthesis (Figure 10) is consistent with DMF formation via dehydration of dimethylammonium formate (eq 12), a mechanism which has been proposed previously.^{45,46}

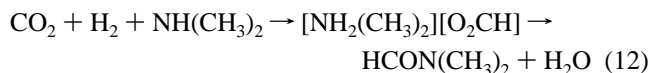

The formate salt intermediate was observed because the second step is rate determining under these conditions. The experiment with D₂ gas, which gave DCON(CH₃)₂, is also consistent with the mechanism shown in eq 12. The same result is inconsistent with a mechanism of the reverse water-gas shift reaction followed by NH(CH₃)₂ carbonylation. These conclusions assume that H/D exchange reactions between D₂ and NH(CH₃)₂ did not occur to any appreciable extent before the DMF was produced. The reaction was stopped at 3% conversion in an attempt to avoid any such exchange processes. The inhibition of the DMF synthesis by an atmosphere of CO (Table 7) seems to rule out the carbonylation mechanism. The extremely low yield of formic acid in this reaction shows that the CO primarily inhibits the hydrogenation step, rather than the dehydration step, presumably by converting the Ru catalyst to less active carbonyl complexes.

Outlook. scCO₂ has been used successfully as an inert medium for a number of stoichiometric reactions of metal complexes^{81,82} and even a few homogeneously catalyzed reactions.¹³ However, the high reactivity of scCO₂ that we have now demonstrated may have consequences for the ability of scCO₂ to serve as an inert medium for catalysis. The insertion of CO₂ into M–H, M–OR, or M–NR₂ bonds (M = metal complex), which is expected to be facile in scCO₂, could alter the catalytic activity of homogeneous catalysts which contain these bonds. Such insertion reactions could lead to catalytically inactive species, suppressing the catalysis, or to CO₂ incorporation reactions where none such was expected. scCO₂ then should no longer be considered “inert” but, depending on the context, would be better described as “reactive”.

Industrial application of CO₂ fixation by hydrogenation is feasible if two conditions can be met: An economical local source of hydrogen is available, and a highly efficient catalyst system can be found. The results described herein prove that

(81) Howdle, S. M.; Poliakoff, M. In *Supercritical Fluids Fundamentals for Application*; Kiran, E., Levelt Sengers, J. M. H., Eds.; NATO ASI Series, Series E 273; Kluwer Academic: Dordrecht, 1994; pp 527–537.

(82) Jessop, P. G.; Ikariya, T.; Noyori, R. *Organometallics* **1995**, *14*, 1510–1513.

homogeneously catalyzed hydrogenation in scCO₂ is both possible and highly efficient, satisfying the second requirement. The ease by which scCO₂ can be hydrogenated suggests that other reactions for the activation of CO₂ or other small molecules could be efficiently performed by homogeneous catalysis in SCFs.

Conclusions

We have demonstrated that scCO₂ is an excellent and promising reaction medium for a homogeneous transition metal-catalyzed reaction. The following more specific conclusions can also be made.

Transition metal complexes of trialkylphosphines are soluble and catalytically active in scCO₂ for the homogeneous hydrogenation of scCO₂. The activity of an analogous triphenylphosphine complex was lower, possibly because of lower solubility. The hydrogenation catalyzed by Ru complex **1** or **2** is both fast and efficient. Yields of up to 1.7 mol of formic acid/mol of a tertiary amine and up to 7200 mol/mol of catalyst can be obtained. The high efficiency and rate of reaction may be due to a number of factors, including the high miscibility of H₂ with scCO₂, a weaker coordination sphere around the catalyst, rapid diffusion in the supercritical phase, and elimination of mass transfer between the gaseous and liquid phases.

The rate of formic acid production is greater if the system is homogeneous and supercritical at the start of the reaction. In general, experiments in which one or more reagents form a second phase had lower rates of reaction. At 50 °C, the highest rate of reaction, 4000 h⁻¹, was obtained with methanol or DMSO additives and represents a considerable advance on the rate mentioned in our preliminary communication.¹²

The formic acid synthesis can be coupled with subsequent reactions of formic acid, for example, with alcohols or secondary amines, to give highly efficient “one-pot” routes to formate esters or formamides. The highest TON value obtained was 420 000 for the synthesis of DMF. The overall rate of DMF formation was up to 8000 h⁻¹ at 100 °C.

Complete understanding of the effect of phase behavior on the rate of reaction could only come with a mapping of the phase diagrams of the ternary system CO₂/H₂/N(C₂H₅)₃ and the quaternary system CO₂/H₂/N(C₂H₅)₃/HCO₂H, a task which can not be performed with our equipment.

The processes described in this report, and any other processes based on homogeneous catalysis in scCO₂, are particularly well suited to industrial application. The high rates of reaction demonstrated in this report are ideal for larger scale continuous flow systems. scCO₂ could also be used to extract the nonpolar catalyst from the polar liquid product stream and thus allow efficient recycling. It is hoped that the high efficiency of the reactions described herein will encourage the use of CO₂-based processes as replacements for those based on toxic carbon monoxide.

Acknowledgment. The authors gratefully acknowledge the experimental work of Dr. K. Aoyagi and Miss M. Kunieda of ERATO and Mr. H. Onishi of the Aichi Institute of Technology. Prof. A. Yamamoto of Waseda University and Dr. S. Hashiguchi and Dr. S. C. A. Neffkens of ERATO provided helpful discussions, while Dr. Y. Yamauchi of JASCO International provided technical assistance.

JA953097B